

SCREWDRIVER





**TEKIRO** has a full range of screwdrivers to suit every job and application. It is very important for a user to choose the right grip, shaft and material for optimum torque and performance.

### 1. SELECT THE GRIP

One of the most important part of a screwdriver is the grip. The grip should fit ergonomically and comfortably into a user's hand. With just a light gripping force, it should generate sufficient torque to fasten or loosen screws with ease without hurting or causing serious injuries.

#### 1.1 MATERIAL

##### A. Plastic (Hard)

Made of Acetate, hard durable material that do not get dirty easily.



##### B. Cushion Rubber (Soft)

Rubberised dimple provides soft and comfortable grip. Ideal for Mechanics with greasy hands.



##### C. PP + TPR

PP + TPR material provides comfortable grip, non slip and best for working with wet and oily hands.



#### 1.2 SHAPE

##### A. Groove Type

Groove type fits comfortably in the hands of users facilitating maximum control and torque.



##### B. Square - Hexagonal Type

Square and hexagonal type have flat surfaces, improves grip and prevent screwdriver from rolling off.





## 2. SELECT THE SHAFT

The shaft is an important component as well as the grip. Select the correct shaft from the 5 points provided below.

### 2.1 GO THRU & NON GO THRU

One piece go through tang suitable for hammer blows at the end of the grip without damaging the tool.

#### A. Go Thru



#### B. Non Go Thru



### 2.3 LENGTH

#### A. Stubby

Short and stout. High torque, more control. Ideal for tight spaces



#### B. Standard

Most commonly used. Suits most jobs and industries.

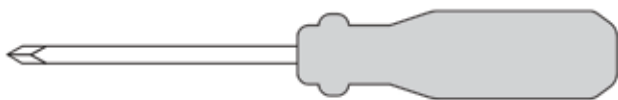

#### C. Long



### 2.2 SHAPE

#### A. Rounded

A common shape that is easy to use when turning while supporting the shaft with the hand.



#### B. Square / Hexagonal

Open end wrenchs can be used for leverage when high turning torque is needed.



### 2.4 MAGNETIC TIPS

Magnetized tip to hold screws and freeing up hand. Useful also for picking up screws



### 2.5 MATERIAL

#### A. SVCM

**(Silicone Vanadium Chrome Molybdenum)**

This material creates high torque, toughness and hardness. Higher than CrV or S2 Steel.

#### B. Cr-V (Chrome Vanadium)

A special steel that has anti-wear properties that are desired in screwdrivers. This is commonly used in most screwdrivers.

## MATERIAL COMPARISON OF SCREWDRIVER

Stress - Strain Curve

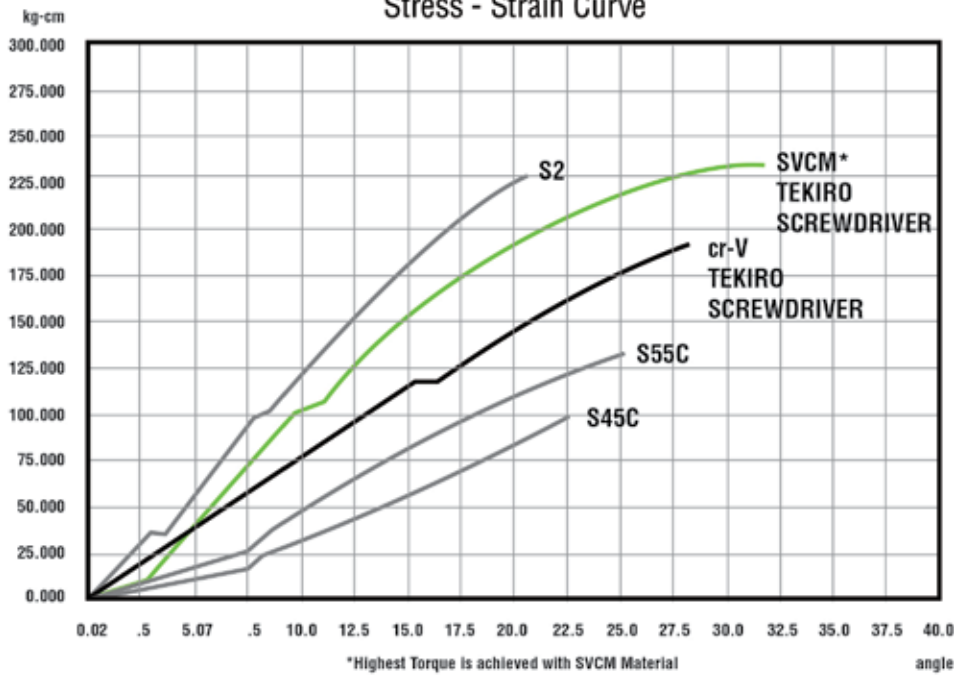

### 3. SELECT THE TIP

TEKIRO screwdriver has 4 tip options. Choose the tip that best fits the type of screw.



Slotted (SL)



Philips (PH)



Pozidriv (Pz)



Torx (T)

## SAFETY INSTRUCTION

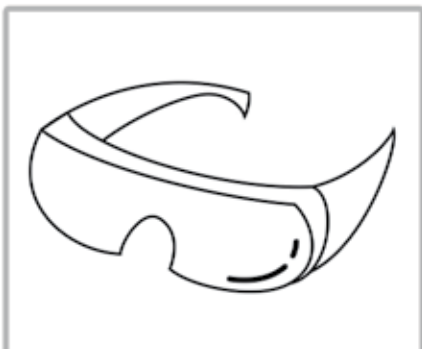

Wear Safety Glasses

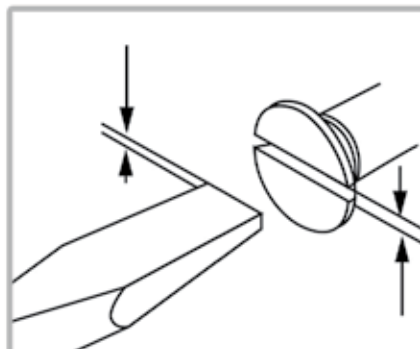

Use the correct end screwdriver for each screw

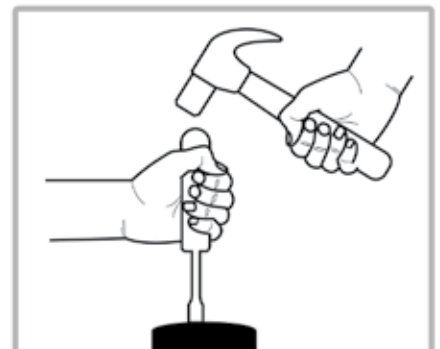

Avoid using screwdrivers as chisels, levers or punches

## IN LINE SCREWDRIVER COLOR

OBENG KRISTAL

ITEM CODE		SIZE		1	2	3	4	5	WEIGHT	QTY / BOX
(+)	(-)	(+)	(-)	(mm)	(mm)	(mm)	(mm)	(mm)	(gr)	INNER/MASTER
SD-IL0789	SD-IL0819	PH00 X 50 mm (Ø 2.5)	2.5 X 50 mm	106	20	14	2	14	14	12 / 600 pcs
SD-IL0790	SD-IL0820	PH00 X 75 mm (Ø 2.5)	2.5 X 75 mm	132	750	15	2	15	15	12 / 600 pcs
SD-IL0791	SD-IL0821	PH00 X 100 mm (Ø 2.5)	2.5 X 100 mm	157	100	13	2	13	16	12 / 600 pcs
SD-IL0792	SD-IL0822	PH0 X 75 mm (Ø 3.2)	3.2 X 75 mm	131	75	14	3	14	17	12 / 600 pcs
SD-IL0793	SD-IL0823	PH0 X 100 mm (Ø 3.2)	3.2 X 100 mm	158	100	14	3	14	19	12 / 600 pcs
SD-IL0794	SD-IL0824	PH0 X 150 mm (Ø 3.2)	3.2 X 150 mm	209	150	15	3	15	22	12 / 600 pcs
SD-IL0795	SD-IL0825	PH0 X 200 mm (Ø 3.2)	3.2 X 200 mm	259	200	14	3	14	25	12 / 600 pcs
SD-IL0796	SD-IL0826	PH0 X 100 mm (Ø 4)	4 X 100 mm	158	100	14	4	14	22	12 / 600 pcs
SD-IL0797	SD-IL0827	PH0 X 125 mm (Ø 4)	4 X 125 mm	183	125	14	4	14	25	12 / 600 pcs
SD-IL0798	SD-IL0828	PH0 X 150 mm (Ø 4)	4 X 150 mm	208	150	14	4	14	28	12 / 600 pcs
SD-IL0799	SD-IL0829	PH0 X 200 mm (Ø 4)	4 X 200 mm	257	200	14	4	14	32	12 / 600 pcs
SD-IL0800	SD-IL0830	PH0 X 250 mm (Ø 4)	4 X 250 mm	303	250	14	4	14	37	12 / 600 pcs
SD-IL0801	SD-IL0831	PH1 X 75 mm (Ø 5)	5 X 75 mm	163	75	20	5	20	48	12 / 300 pcs
SD-IL0802	SD-IL0832	PH1 X 100 mm (Ø 5)	5 X 100 mm	190	100	20	5	20	55	12 / 300 pcs
SD-IL0803	SD-IL0833	PH1 X 125 mm (Ø 5)	5 X 125 mm	214	125	20	5	20	59	12 / 300 pcs
SD-IL0804	SD-IL0834	PH1 X 150 mm (Ø 5)	5 X 150 mm	242	150	20	5	20	62	12 / 300 pcs
SD-IL0805	SD-IL0835	PH1 X 200 mm (Ø 5)	5 X 200 mm	290	200	20	5	20	71	12 / 240 pcs
SD-IL0806	SD-IL0836	PH1 X 250 mm (Ø 5)	5 X 250 mm	340	250	20	5	20	78	12 / 240 pcs
SD-IL0807	SD-IL0837	PH1 X 300 mm (Ø 5)	5 X 300 mm	390	300	20	5	20	84	12 / 240 pcs
SD-IL0808	SD-IL0838	PH2 X 38 mm (Ø 6)	6 X 38 mm	87	38	26	6	26	44	12 / 300 pcs
SD-IL0809	SD-IL0839	PH2 X 100 mm (Ø 6)	6 X 100 mm	198	100	22	6	22	77	12 / 300 pcs
SD-IL0810	SD-IL0840	PH2 X 125 mm (Ø 6)	6 X 125 mm	224	125	22	6	22	81	12 / 300 pcs
SD-IL0811	SD-IL0841	PH2 X 150 mm (Ø 6)	6 X 150 mm	249	150	22	6	22	89	12 / 300 pcs
SD-IL0812	SD-IL0842	PH2 X 200 mm (Ø 6)	6 X 200 mm	299	200	22	6	22	98	12 / 240 pcs
SD-IL0813	SD-IL0843	PH2 X 250 mm (Ø 6)	6 X 250 mm	351	250	22	6	22	109	12 / 240 pcs
SD-IL0814	SD-IL0844	PH2 X 300 mm (Ø 6)	6 X 300 mm	398	300	22	6	22	120	12 / 240 pcs
SD-IL0815	SD-IL0845	PH3 X 150 mm (Ø 8)	8 X 150 mm	262	150	26	8	26	140	12 / 120 pcs
SD-IL0816	SD-IL0846	PH3 X 200 mm (Ø 8)	8 X 200 mm	312	200	26	8	26	157	12 / 120 pcs
SD-IL0817	SD-IL0847	PH3 X 250 mm (Ø 8)	8 X 250 mm	365	250	26	8	26	174	12 / 120 pcs
SD-IL0818	SD-IL0848	PH3 X 300 mm (Ø 8)	8 X 300 mm	398	300	26	8	26	192	12 / 120 pcs

- Material chrome vanadium
- Grip is made of Acetate material, hard and durable.

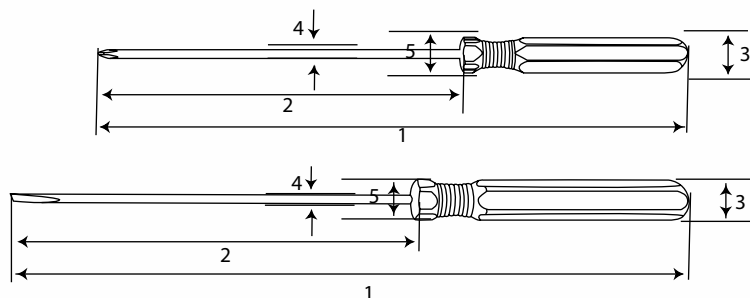

WRENCH

TORQUE

SOCKET

IMPACT SOCKET

PLIER

SCREWDRIVER



### CUSHION GRIP SCREWDRIVER

The **TEKIRO** Cushion Grip screwdriver is constructed with a chrome vanadium steel for the shaft and SVCM steel for a magnetic tip for convenience when working. Features include a non-slip rubber cushion grip to give total control and comfort during operation.

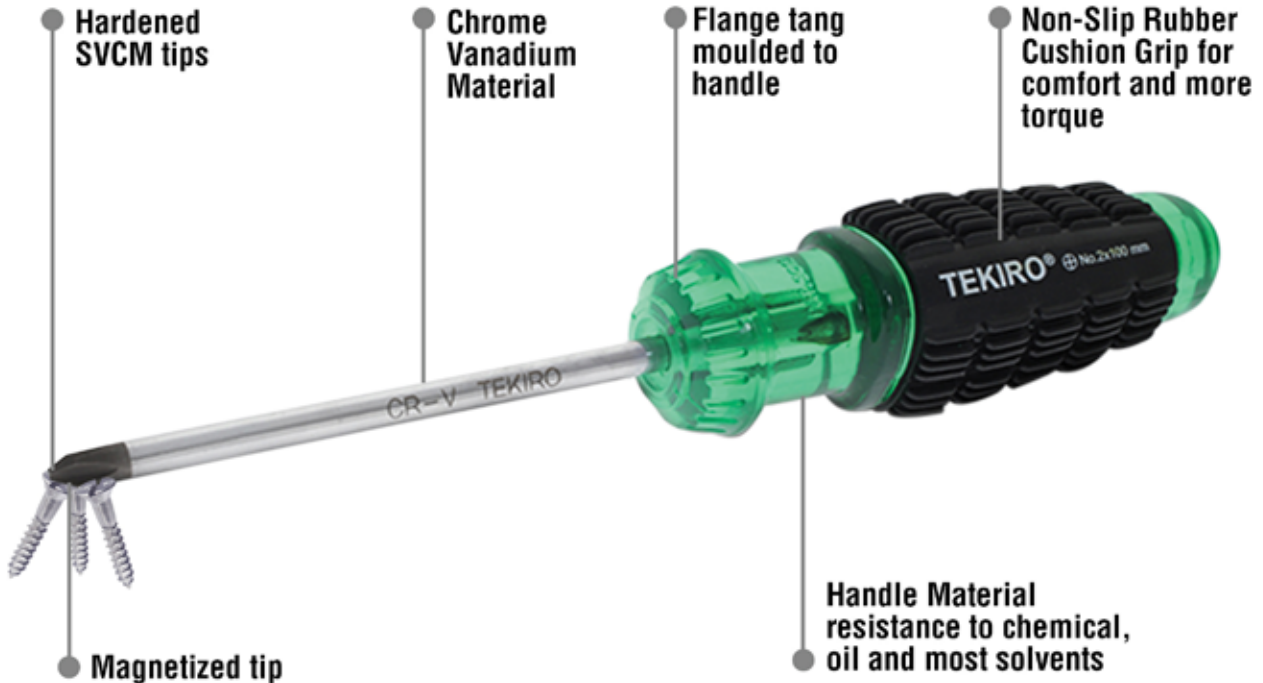

### TPR SCREWDRIVER

**TEKIRO** TPR Screwdriver features a unique ergonomic hand moulded design handle with a combination of PP and TPR bi-material grip to promote comfort and high torque. It is also highly resistant against chemicals, oil and most solvents.

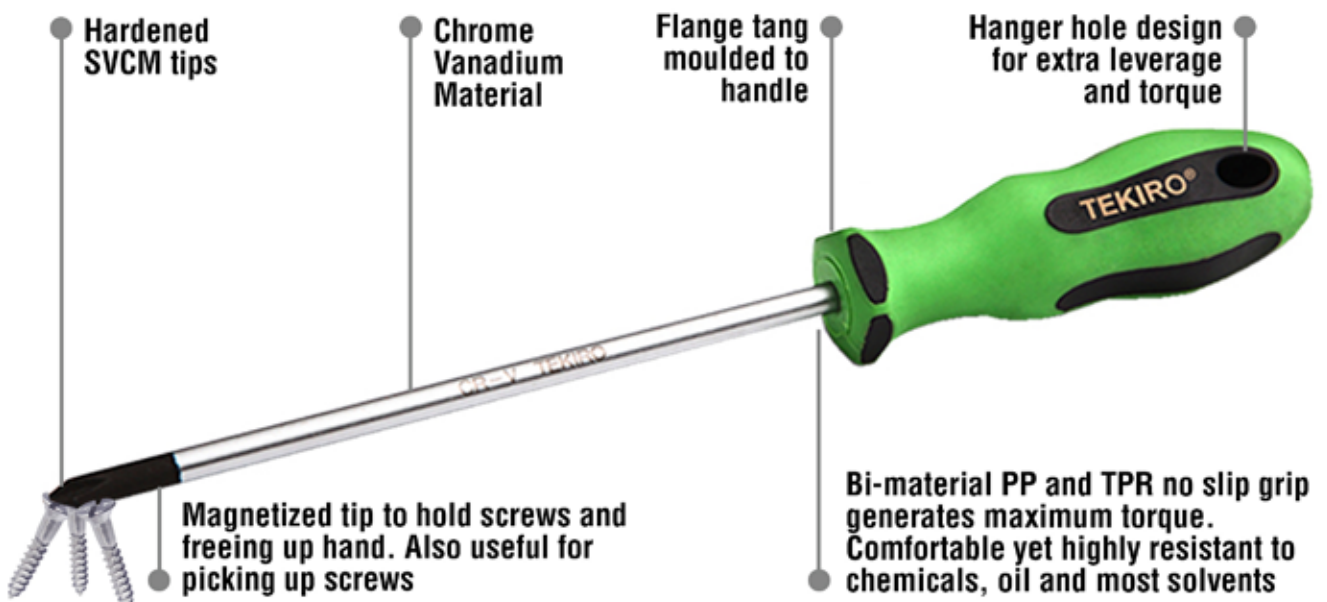



## CUSHION GRIP SCREWDRIVER

OBENG GAGANG KARET

ITEM CODE		SIZE		1	2	3	4	5	WEIGHT	QTY / BOX
(+)	(-)	(+)	(-)	(mm)	(mm)	(mm)	(mm)	(mm)	(gr)	INNER/MASTER
SD-CG0850	SD-CG0858	PH1 X 75 mm (Ø 5)	5 X 75 mm	175	75	22	5	31	84	12 / 120 pcs
SD-CG0851	SD-CG0859	PH2 X 38 mm (Ø 6)	6 X 38 mm	100	38	27	6	31	66	12 / 300 pcs
SD-CG0852	SD-CG0860	PH2 X 100 mm (Ø 6)	6 X 100 mm	210	100	25	6	31	113	12 / 120 pcs
SD-CG0853	SD-CG0861	PH2 X 125 mm (Ø 6)	6 X 125 mm	234	125	28	6	31	119	12 / 120 pcs
SD-CG0854	SD-CG0862	PH2 X 150 mm (Ø 6)	6 X 150 mm	258	150	30	6	31	124	12 / 120 pcs
SD-CG0855	SD-CG0863	PH2 X 200 mm (Ø 6)	6 X 200 mm	310	200	30	6	31	135	12 / 120 pcs
SD-CG0856	SD-CG0864	PH2 X 250 mm (Ø 6)	6 X 250 mm	361	250	25	6	31	145	12 / 120 pcs
SD-CG0857	SD-CG0865	PH2 X 300 mm (Ø 6)	6 X 300 mm	410	300	30	6	31	156	12 / 120 pcs

- Larger, comfortable grip
- Generates extreme Torque
- Favourite with mechanics with oily hands

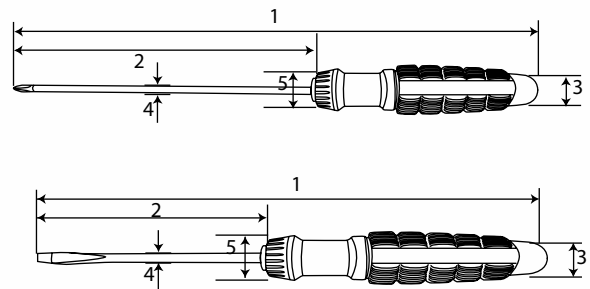

## GO THRU SCREWDRIVER GREEN HANDLE

OBENG TEMBUS HIJAU

ITEM CODE		SIZE		1	2	3	4	5	WEIGHT	QTY / BOX
(+)	(-)	(+)	(-)	(mm)	(mm)	(mm)	(mm)	(mm)	(gr)	INNER/MASTER
SD-GT0866	SD-GT0874	PH1 X 75 mm (Ø 5)	5 x 75 mm	164	75	20	5	17	59	12 / 300 pcs
SD-GT0867	SD-GT0875	PH2 X 100 mm (Ø 6)	6 x 100 mm	200	100	26	6	24	105	12 / 240 pcs
SD-GT0868	SD-GT0876	PH2 X 125 mm (Ø 6)	6 x 125 mm	225	125	26	6	24	112	12 / 240 pcs
SD-GT0869	SD-GT0877	PH2 X 150 mm (Ø 6)	6 x 150 mm	253	150	26	6	24	120	12 / 240 pcs
SD-GT0870	SD-GT0878	PH2 X 200 mm (Ø 6)	6 x 200 mm	306	200	26	6	24	134	12 / 240 pcs
SD-GT0871	SD-GT0879	PH3 X 200 mm (Ø 8)	8 x 200 mm	312	200	27	8	26	209	12 / 120 pcs
SD-GT0872	SD-GT0880	PH3 X 250 mm (Ø 8)	8 x 250 mm	360	250	27	8	26	234	12 / 120 pcs
SD-GT0873	SD-GT0881	PH3 X 300 mm (Ø 8)	8 x 300 mm	413	300	27	8	26	256	12 / 120 pcs

- Material : CrV
- Shaft : Square type
- Grip Material: PVC
- This screwdriver is trusted by mechanics for decades  
It is used together with hammers to loosen screws with some impact

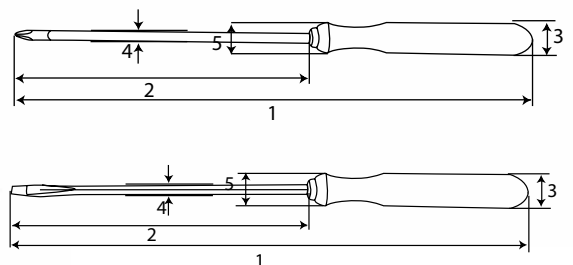

WRENCH

TORQUE

SOCKET

IMPACT SOCKET

PLIER

SCREWDRIVER

## TPR SCREWDRIVER

OBENG TPR

ITEM CODE		SIZE		1	2	3	4	5	WEIGHT	QTY / BOX
(+)	(-)	(+)	(-)	(mm)	(mm)	(mm)	(mm)	(mm)	(gr)	INNER/MASTER
SD-TR0882	SD-TR0898	PH0 X 150 mm (Ø 3)	3 X 150 mm	221	150	21	3	17	23	12 / 600 pcs
SD-TR0883	SD-TR0899	PH0 X 200 mm (Ø 3)	3 X 200 mm	270	200	21	3	17	28	12 / 600 pcs
SD-TR0884	SD-TR0900	PH0 X 100 mm (Ø 4)	4 X 100 mm	210	100	22	4	22	27	12 / 600 pcs
SD-TR0885	SD-TR0901	PH0 X 150 mm (Ø 4)	4 X 150 mm	219	150	22	4	22	32	12 / 600 pcs
SD-TR0886	SD-TR0902	PH0 X 200 mm (Ø 4)	4 X 200 mm	262	200	22	4	22	36	12 / 600 pcs
SD-TR0888	SD-TR0903	PH1 X 75 mm (Ø 5)	5 X 75 mm	176	75	25	5	25	61	12 / 300 pcs
SD-TR0889	SD-TR0904	PH1 X 100 mm (Ø 5)	5 X 100 mm	201	101	26	6	26	63	12 / 300 pcs
SD-TR0890	SD-TR0905	PH1 X 125 mm (Ø 5)	5 X 125 mm	236	127	30	6	27	133	12 / 300 pcs
SD-TR0891	SD-TR0906	PH1 X 150 mm (Ø 5)	5 X 150 mm	256	150	25	5	25	72	12 / 240 pcs
SD-TR0892	SD-TR0907	PH2 X 38 mm (Ø 6)	6 X 38 mm	103	38	32	6	26	44	12 / 300 pcs
SD-TR0893	SD-TR0908	PH2 X 100 mm (Ø 6)	6 X 100 mm	209	100	31	6	31	87	12 / 240 pcs
SD-TR0894	SD-TR0909	PH2 X 125 mm (Ø 6)	6 X 125 mm	245	125	31	6	31	91	12 / 180 pcs
SD-TR0887	SD-TR0910	PH2 X 150 mm (Ø 6)	6 X 150 mm	260	150	31	6	31	97	12 / 180 pcs
SD-TR0895	SD-TR0911	PH2 X 200 mm (Ø 6)	6 X 200 mm	310	200	31	6	31	108	12 / 120 pcs
SD-TR0896	SD-TR0912	PH2 X 250 mm (Ø 6)	6 X 250 mm	355	252	31	6	28	118	12 / 120 pcs
SD-TR0897	SD-TR0913	PH2 X 300 mm (Ø 6)	6 X 300 mm	408	300	31	6	31	129	12 / 120 pcs

- SVCM material steel blade is better than CrV in terms of hardness and generating torque
- PP+ TPR material prevents slippage, and highly resistance to oil and most solvents
- Blades are chrome plated with satin finishing for rust prevention
- Highly precise tip-end magnetized and black oxide finish for extra durability

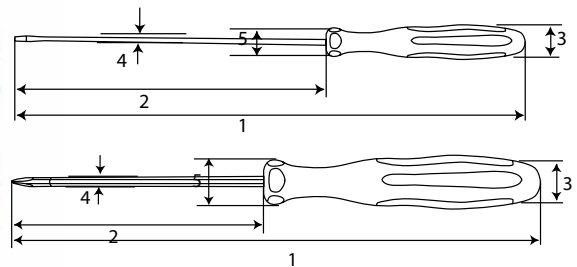

## TPR EXTRA LONG SCREWDRIVER

OBENG TPR EXTRA PANJANG

ITEM CODE	SIZE	1	2	3	4	5	WEIGHT	QTY / BOX
		(mm)	(mm)	(mm)	(mm)	(mm)	(gr)	INNER/MASTER
SD-TE1502	(-) 5.5 X 400 MM	500	400	30	5	24	117.5	12 / 72 pcs
SD-TE1503	(+) PH1 X 400MM (5)	500	400	30	5	24	117.5	12 / 72 pcs
SD-TE1630	(+) PH2 X 400MM (6)	510	400	29	6	27	117.5	12 / 72 pcs

- SVCM material steel blade is better than CrV in terms of hardness and generating torque
- PP+ TPR material prevents slippage, and highly resistance to oil and most solvents
- Blades are chrome plated with satin finishing for rust prevention
- Highly precise tip-end magnetized and black oxide finish for extra durability
- Extra long for greater access and reaching tight deep spaces
- Parallel tip on slotted screwdriver

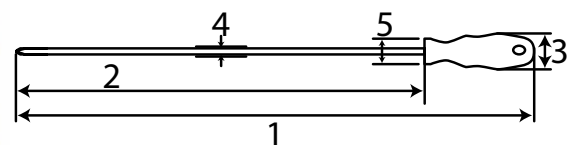



**TPR GO THRU SCREWDRIVER**

**TEKIRO** TPR Go-Thru screwdriver combines the advantages of the TPR design handle with a one-piece tang shaft from tip to grip. Ideal for hammer blows.

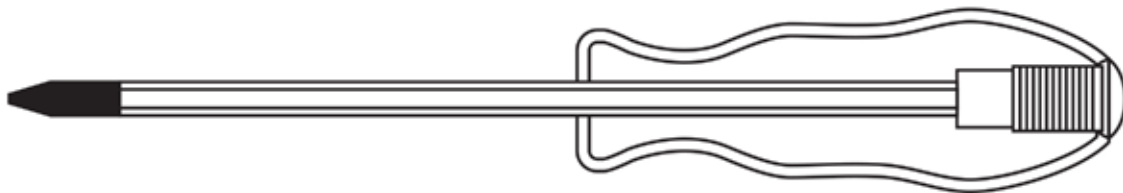
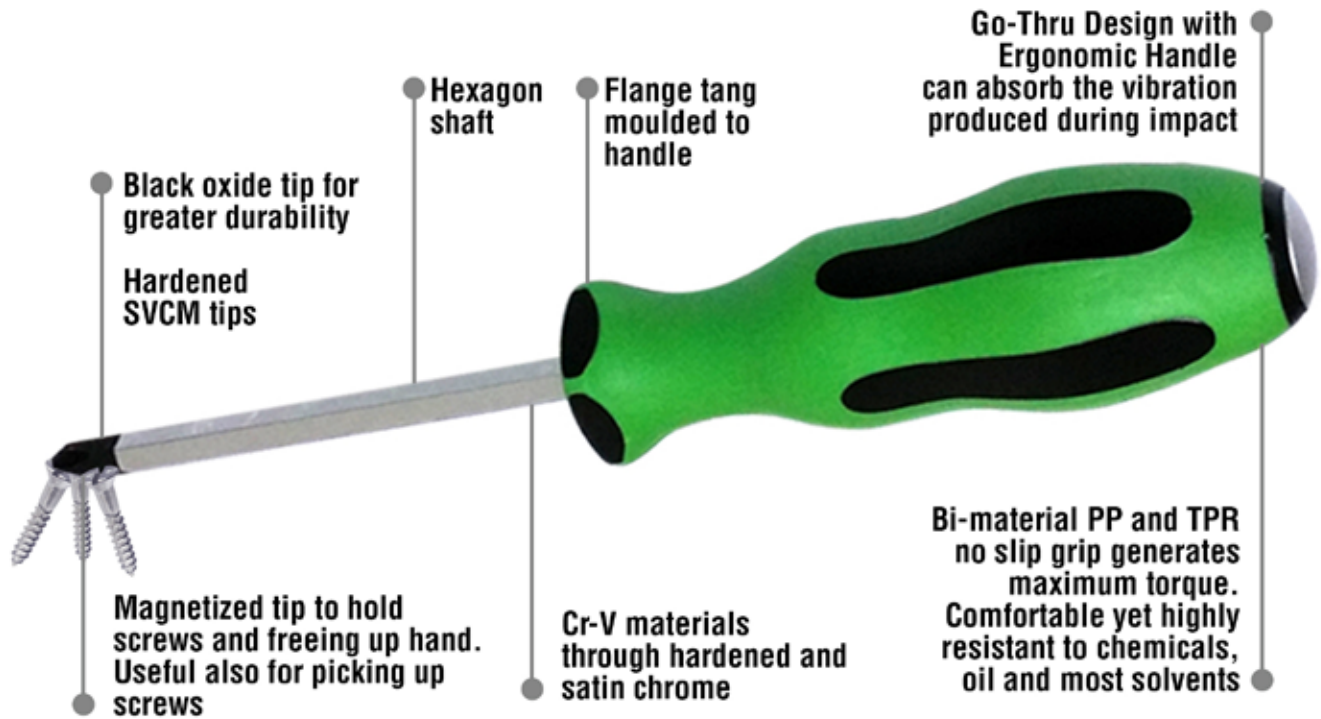

One-piece tang thru designed specifically for hammer blows to deliver shock directly to the screws



WRENCH

TORQUE

SOCKET

IMPACT SOCKET

PLIER

**SCREWDRIVER**

## TPR GO THRU SCREWDRIVER

OBENG TPR TEMBUS

ITEM CODE		SIZE		1	2	3	4	5	WEIGHT	QTY / BOX
(+)	(-)	(+)	(-)	(mm)	(mm)	(mm)	(mm)	(mm)	(gr)	INNER/MASTER
SD-TG0940	SD-TG0948	PH1 x 75 mm (Ø5)	5 x 75 mm	175	76	30	5	25	86	12 / 240 pcs
SD-TG0941	SD-TG0949	PH2 x 100 mm (Ø6)	6 x 100 mm	210	100	32	6	27	128	12 / 180 pcs
SD-TG0942	SD-TG0950	PH2 x 125 mm (Ø6)	6 x 125 mm	237	128	27	6	27	133	12 / 180 pcs
SD-TG0943	SD-TG0951	PH2 x 150 mm (Ø6)	6 x 150 mm	261	150	27	6	27	143	12 / 180 pcs
SD-TG0944	SD-TG0952	PH2 x 200 mm (Ø6)	6 x 200 mm	310	203	27	6	27	153	12 / 120 pcs
SD-TG0945	SD-TG0953	PH3 x 200 mm (Ø8)	8 x 200 mm	320	201	32	8	30	237	6 / 96 pcs
SD-TG0946	SD-TG0954	PH3 x 250 mm (Ø8)	8 x 250 mm	370	252	31	8	30	259	6 / 72 pcs
SD-TG0947	SD-TG0955	PH3 x 300 mm (Ø8)	8 x 300 mm	420	300	32	8	30	280	6 / 72 pcs

- One Piece tang thru for impact and hammer blows
- SVCM material steel blade is better than CrV in terms of hardness and generating torque.
- PP+ TPR material prevents slippage, and highly resistance to oil and most solvents
- Blades are chrome plated with satin finishing for rust prevention
- Shaft is hexagon shaped for greater strength
- Highly precise tip-end magnetized and black oxide finish for extra durability

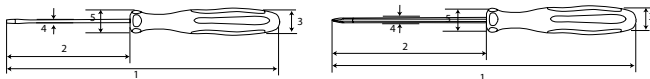

## 2 WAY SCREWDRIVER

OBENG DUA ARAH

ITEM CODE	SIZE		1	2	3	4	5	WEIGHT	QTY / BOX
	(+)	(-)	(mm)	(mm)	(mm)	(mm)	(mm)		
SD-TW0849	PH2 X 125 mm	6 X 125 mm	111	12	150	31	11	130	12 / 120 pcs

- 2 in 1 fuction for convenient use
- 2 - tone big handle for holding well
- Highly durable

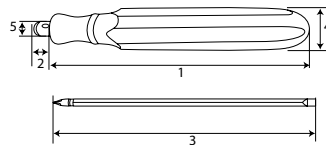

## TPR 2 WAY SCREWDRIVER

OBENG TPR DUA ARAH

ITEM CODE	SIZE		1	2	3	4	5	WEIGHT	QTY / BOX
	(+)	(-)	(mm)	(mm)	(mm)	(mm)	(mm)		
SD-TR0957	PH2 x 125 mm	6 x 125 mm	123	30	28	143	6	105	6 / 48 pcs

- SVCM material steel blade is better than CrV in terms of hardness and generating torque
- PP+TPR material prevents slippage, and highly resistance to oil and most solvents
- Blades are chrome plated with satin finishing for rust prevention
- Shaft is hexagon shaped for greater strength
- Interchangeable tip (+) & (-) on respective ends for portability and convenience



## 2 IN 1 STUBBY SCREWDRIVER

OBENG STUBBY DUA ARAH

ITEM CODE	SIZE		1 (mm)	2 (mm)	3 (mm)	4 (mm)	WEIGHT (gr)	QTY / BOX INNER/MASTER
	(+)	(-)						
SD-SS1466	PH2 x 65mm	6 x 65mm	68	65	32	14	45	6 / 48 pcs

- 2 In1 function for convenient use
- Suitable for narrow space using
- Bi-material handle for holding well

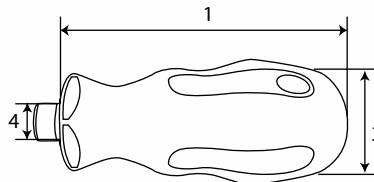
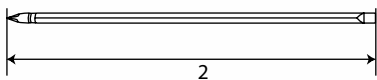

## INSULATION PRECISION SCREWDRIVER SET 6 PCS

OBENG LISTRIK PRESISI SET 6 PCS

ITEM CODE	CONTENT	WEIGHT (gr)	QTY / BOX INNER/MASTER
SD-IP0930	3 pcs Precision Screwdriver Slotted 25 mm (-) 1.4 mm, 1.8 mm, 2.4 mm	254	12 / 48 pcs
	3 pcs Precision Screwdriver Philips 25 mm (+) PH00, PH0, (+) PH1		

- Heat treated chrome vanadium
- Rotate cap
- Multiple size



## 12 IN 1 PRECISION SCREWDRIVER SET

OBENG SET 12 IN 1

ITEM CODE	CONTENT	WEIGHT (gr)	QTY / BOX INNER/MASTER
SD-PR0933	3 pcs Precision Screwdriver Slotted 120 mm (-) 2.0 mm, 3.0 mm, 4.0 mm	190	12 / 96 set
	3 pcs Precision Screwdriver Philips 120 mm (+) PH00, PH0, (+) PH1		
	6 pcs Torx Bits 120 mm T5, T6, T8, T10, T15, T20		

- Heat treated chrome vanadium
- Rotate cap
- Multiple size



WRENCH

TORQUE

SOCKET

IMPACT SOCKET

PLIER

SCREWDRIVER



## PRECISION SCREWDRIVER SET 6 PCS

### OBENG SET 6 PCS

ITEM CODE	CONTENT	WEIGHT (gr)	QTY / BOX INNER/MASTER
SD-PE0937	3 pcs Precision Screwdriver Slotted 25 mm (-) 1.4, 1.8, 2.4	155	12 / 96 set
	3 pcs Precision Screwdriver Philips 25 mm (+) PH00, PH0, PH1		

- High quality rubber handle
- Durable
- Multiple size



## PRECISION SCREWDRIVER SET 30 PCS

### OBENG SET PRESISI 30 PCS



ITEM CODE	CONTENT	WEIGHT (gr)	QTY / BOX INNER/MASTER
SD-PS0936	9 pcs Torx Bits T4, T5, T6, T7, T8, T9, 10, T15, T20	235	6 / 36 set
	8 pcs Hex Bits 0.7 mm, 0.9 mm, 1.3 mm, 1.5 mm 2.0 mm, 2.5 mm, 3.0 mm, 4.0 mm		
	7 pcs Slotted Bits (-) 1.0 mm, 1.5 mm, 2.0 mm, 2.5 mm, 3.0 mm, 3.5 mm, 4.0 mm		
	4 pcs Philips Bits (+) PH000, PH00, PH0, PH1		
	2 pcs Pozi Bits PZ0, PZ1		

- High quality rubber handle
- Durable
- Multiple size



## GO THRU SCREWDRIVER SET 7 PCS

### OBENG TEMBUS SET 7 PCS



ITEM CODE	CONTENT	WEIGHT (gr)	QTY / BOX INNER/MASTER
SD-GT0932	4 pcs Go Thru Screwdriver Slotted (-) 5.0 x 75 mm, 6.0 x 100 mm (-) 6.0 x 150 mm, 8.0 x 200 mm	889	6 / 24 set
	3 pcs Go Thru Screwdriver Philips (+) PH1 x 75 mm, PH2 x 100 mm (+) PH3 x 150 mm		

- Durable
- Multiple size





## TPR GO THRU SCREWDRIVER SET 7 PCS

OBENG TPR TEMBUS SET 7 PCS

ITEM CODE	CONTENT	WEIGHT (gr)	QTY / BOX INNER/MASTER
SD-TG0956	4 pcs Go Thru Screwdriver Slotted (-) 5.0 x 75 mm, 6.0 x 100 mm (-) 8.0 x 150 mm, 9.5 x 200 mm	1,200	4 / 16 set
	3 pcs Go Thru Screwdriver Philips (+) PH1 x 75 mm, PH2 x 100 mm (+) PH3 x 150 mm		



## IN LINE COLOR SCREWDRIVER SET 7 PCS

OBENG KRISTAL SET 7 PCS

ITEM CODE	CONTENT	WEIGHT (gr)	QTY / BOX INNER/MASTER
SD-IL0935	4 pcs In Line Screwdriver Slotted (-) 2.5 x 100 mm, 6.0 x 38 mm (-) 6.0 x 100 mm, 8.0 x 150 mm	254	10 / 40 set
	3 pcs In Line Screwdriver Philips (+) PH2 x 38 mm, PH2 x 100 mm (+) PH3 x 150 mm		

- Chrome vanadium finish
- High quality plastic handle
- High durable hardness



## CUSHION GRIP SCREWDRIVER 7 PCS

OBENG GAGANG KARET SET 7 PCS

ITEM CODE	CONTENT	WEIGHT (gr)	QTY / BOX INNER/MASTER
SD-CG0934	4 pcs Cushion Grip Screwdriver Slotted (-) 5.0 x 75 mm, 6.0 x 38 mm (-) 6.0 x 100 mm, 6.0 x 150 mm	874	5 / 25 set
	3 pcs Cushion Grip Screwdriver Philips (+) PH1 x 75 mm, PH2 x 100 mm (+) PH2 x 150 mm		

- Material is SVCM steel blade is better than CR-V hardness and torsion
- Anti slip handle
- High quality plastic & rubber handle



WRENCH

TORQUE

SOCKET

IMPACT SOCKET

PLIER

SCREWDRIVER

## INSULATION SCREWDRIVER SET 7 PCS

OBENG LISTRIK SET 7 PCS



ITEM CODE	CONTENT	WEIGHT (gr)	QTY / BOX INNER/MASTER
SD-EL0938	4 pcs Insulation Screwdriver Slotted (-) 4.0 x 100 mm, 5.5 x 125 mm (-) 6.5 x 150 mm, 8.0 x 150 mm	811	6 / 18 set
	3 pcs Insulation Screwdriver Philips (+) PH1 x 80 mm, PH2 x 100 mm (+) PH3 x 150 mm Auto Voltage Tester		

- High quality rubber handle
- Anti slip handle
- Safe for medium voltage

## IMPACT DRIVER SET 5 PCS PE BOX

OBENG KETOK 5 PCS BOX PE (PLASTIK)



ITEM CODE	CONTENT	1 (mm)	2 (mm)	WEIGHT (gr)	QTY / BOX INNER/MASTER
SD-IM1698	1 pcs Impact Driver	157	30	173	1 / 20 set
	2 pcs Impact Bit 80 mm Slotted (-) 8.0, 10.0				
	2 pcs Impact Bit 80 mm Philips (+) PH2, PH3				

- High durable hardness
- Comfort grip
- Strong for hard impact
- With blow mould case

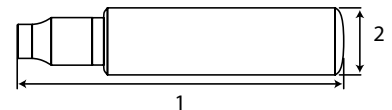

## MINI IMPACT DRIVER AND EXTRACTOR SET 7 PCS

OBENG KETOK MINI 7 PCS



ITEM CODE	CONTENT	1 (mm)	2 (mm)	3 (mm)	WEIGHT (gr)	QTY / BOX INNER/MASTER
SD-MI1691	1 pcs Mini Impact Driver	135	17	10	331.5	12 / 48 pcs
	3 pcs 1/4" x 50 mm Impact Bits (+) PH1, PH2, (-) 5 mm					
	3 pcs 1/4" x 50 mm Screw Extractor No.1 - 1/8" - 1/4" (M3-M6) No.2 - 1/4" - 5/16" (M6-M8) No.3 - 5/16" - 7/16" (M8-M11)					

- High durable hardness
- Comfort grip
- Strong for hard impact
- CR-V is used for bit material
- Light & easy to use and especially for loosening tightly fastened bolt or rusted bolts

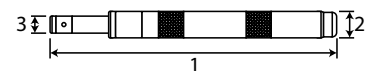

## IMPACT DRIVER SET 9 PCS

### OBENG KETOK SET 9 PCS

ITEM CODE	CONTENT	WEIGHT (gr)	QTY / BOX INNER/MASTER
SD-IM0922	1 pcs Impact Driver	1,130	1 / 18 set
	2 pcs Impact Bit Slotted 36 mm (-) 8.0 , 10.0		
	2 pcs Impact Bit Philips 36 mm (+) PH2, PH3		
	1 pcs Impact Bit Slotted 80 mm (-) 8.0		
	3 pcs Impact Bit Philips 80 mm (+) PH2, PH3, PH4		



- High durable hardness
- Comfort grip
- Strong for hard impact
- With plastic tray

## IMPACT DRIVER SET 11 PCS

### OBENG KETOK SET 11 PCS

ITEM CODE	CONTENT	WEIGHT (gr)	QTY / BOX INNER/MASTER
SD-IM0921	1 pcs Impact Driver	1,160	1 / 10 set
	2 pcs Impact Bit Slotted 36 mm (-) 8.0 , 10.0		
	2 pcs Impact Bit Philips 36 mm (+) PH2, PH3		
	2 pcs Impact Bit Slotted 80 mm (-) 8.0 , 10.0		
	2 pcs Impact Bit Philips 80 mm (+) PH2, PH3		
	2 pcs Screw Extractor No.3 - 5/16" - 7/16" (M8-M11)		
	No.4 - 7/16" - 9/16" (M11-M14)		



- High durable hardness
- Comfort grip
- Strong for hard impact
- With blow mould case

## HEAVY DUTY IMPACT BITS SET 12 PCS

### MATA OBENG KETOK SET 12 PCS

ITEM CODE	SIZE	WEIGHT (gr)	QTY / BOX INNER/MASTER
SD-IB0924	PH 2 (+)	363	10 / 60 set
SD-IB1287	PH 3 (+)	363	10 / 60 set
SD-IB0925	PH 2 (-)	363	10 / 60 set



- S2 Materials

WRENCH

TORQUE

SOCKET

IMPACT SOCKET

PLIER

SCREWDRIVER

**19 IN 1 INTERCHANGEABLE SCREWDRIVER SET**

Convenient ratcheting screwdriver with multiple screwdriver bits in one tool. High turning ratio mechanism reduces fatigue and increases the speed of tightening or loosening screws with every single turn.



**Perfect Handle Design**



**High Quality Ratchet**



**Integrated Storage**



**Multifunctions**



## 19 IN 1 INTERCHANGEABLE SCREWDRIVER SET

OBENG SET 19 IN 1

ITEM CODE	CONTENT	WEIGHT (gr)	QTY / BOX INNER/MASTER
SD-IS1465	2 pcs 1/4"x75 mm Precision Bit (-) 2.0 & (+) PH00	387	6 / 48 set
	12 pcs 1/4"x75 mm Double End Bit (-) 4.0 & (+) PH0 (-) 5.0 & (+) PH1 (-) 6.0 & (+) PH2 (+) PH1 & (+) PH2		
	2.5 mm, 3.0 mm 4.0 mm, 5.0 mm		
	2 pcs 5/16"x75 mm Double End Bit (-) 8.0 & (+) PH3		
	2 pcs Nut Driver on Tube 1/4" & 5/16"		
	1 pcs Nut Driver on Ratchet 7/16"		



- Integrated storage
- High quality ratchet
- Perfect handle design
- Ratchet mechanism that's capable of quick turning in both tightening and loosening direction

## STUBBY RATCHET AND BITS SET 7 IN 1

OBENG RATCHET STUBBY SET 7 IN 1

ITEM CODE	CONTENT	1 (mm)	2 (mm)	3 (mm)	4 (mm)	WEIGHT (gr)	QTY / BOX INNER/MASTER
SD-SR1699	1 pcs Stubby Ratchet Bit Driver	79	17	35	9	333	6 / 48 pcs
	3 pcs 1/4" x 25 mm Bits (+) PH1, PH2, PH3						
	3 pcs (-) 3.0, 4.0, 5.0, 6.0 mm						

- High quality handle for comfort grip
- Multiple tip
- Durable
- Convenient for attaching / detaching screw in narrow spaces
- 2 way ratcheting mechanism. For easy tightening and loosening screws with just a quick turn of the knob for changing direction.

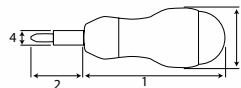

## DOUBLE ENDED SCREW DRIVER BIT SET 10 PCS

MATA OBENG ANGIN SET 10 PCS

ITEM CODE	SIZE	WEIGHT (gr)	QTY / BOX INNER/MASTER
SD-DE0958	PH1 X 65	235	12 / 48 set
SD-DE0927	PH2 X 65	233	12 / 48 set
SD-DE0928	PH2 X 110	268	10 / 60 set
SD-DE0929	PH2 (-) 6 X 65	232	12 / 48 set

- High hardness
- Durable
- Easy storage



WRENCH

TORQUE

SOCKET

IMPACT SOCKET

PLIER

SCREWDRIVER

## SCREW EXTRACTOR SET 6 PCS

### TAP BALIK SET 6 PCS



ITEM CODE	CONTENT	WEIGHT (gr)	QTY / BOX INNER/MASTER
SD-EX0926	6 pcs Screw Extractor	215	10 / 100 set
	No.1 - 1/8" - 1/4" (M3-M6)		
	No.2 - 1/4" - 5/16" (M6-M8)		
	No.3 - 5/16" - 7/16" (M8-M11)		
	No.4 - 7/16" - 9/16" (M11-M14)		
	No.5 - 9/16" - 3/4" (M14-M18)		
No.6 - 3/4" - 1" (M18-M25)			

- Easy to use
- Highly durable
- Multiple size
- To remove damaged screw heads

## MINI POCKET SCREWDRIVER 4 IN 1

### OBENG TYPE PEN 4 IN 1



ITEM CODE	CONTENT	1 (mm)	2 (mm)	WEIGHT (gr)	QTY / BOX INNER/MASTER
SD-MP1692	2 pcs Precision Screwdriver 52 mm (-)1.6 (+)PH00	130	52	29.0	50 / 200 pcs
	2 pcs Precision Screwdriver 130 mm (-)3.0 (+)PH0				

- High quality plastic
- Durable
- Easy to use
- CR-V MATERIALS
- Light & easy to use and can put in your pocket
- Mobile phone, glassess watch usage

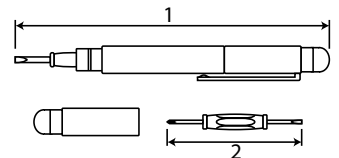

## MAGNETIC HEX NUT

### KUNCI MATA ROOFING



ITEM CODE	SIZE	1 (mm)	2 (mm)	3 (mm)	4 (mm)	WEIGHT (gr)	QTY / BOX INNER/MASTER
SD-MH1406	6 X 65 mm	65	11	6	6	190	10 / 60 set
SD-MH1407	8 X 65 mm	65	13	6	8	192	10 / 60 set
SD-MH1408	10 X 65 mm	65	11	6	10	174	10 / 60 set

- Heat treated for high torque strength
- Silver matt finishing

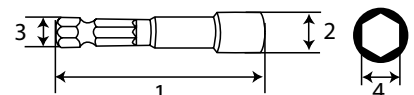

**BELIEVE**  
**IN YOUR CHOICE**

**WWW.TEKIRO.COM**